



ESPECIFICACIONES

- ✓ Cuerpo del luminario: Metal y cristal.
- ✓ Tecnología: LED tipo SMD 2835/0.5W
- ✓ No usar con dimmers o controladores de movimiento.
- ✓ Montaje: Ajustable a brazo 1 ¼" y 1 ½"
- ✓ Horas de Vida: 20,000 Hrs.
- ✓ IP: 65
- ✓ 1 años de Garantía

Potencia	Lúmenes	Eficiencia	IRC	TDC	Voltaje
60W	4,860	81 m/W	>50	6500K	100-240V

APLICACIONES

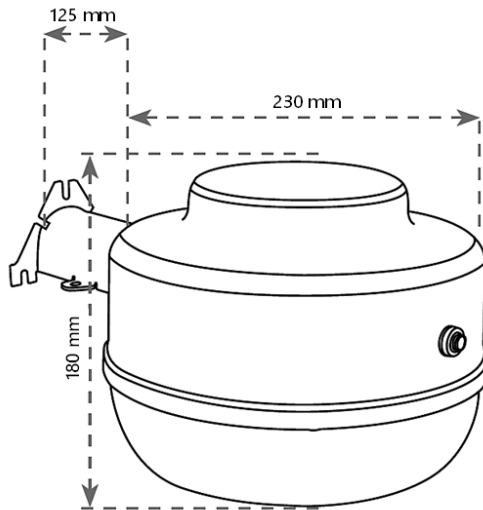

CALLES Y AVENIDAS



ESTACIONAMIENTO



PARQUES Y JARDINES



ANDADORES, PATIOS, CORREDORES Y PASILLOS



ÁREAS RECREATIVAS



COTOS Y ZONAS RESIDENCIALES